

Drawn by: RM
Date: FEB / 2002
REVISIONS:
Feb 2004 - RM
Feb 2005 - RM
Feb 2006 - RM
Jan 2007 - TD
Feb 2007 - TD

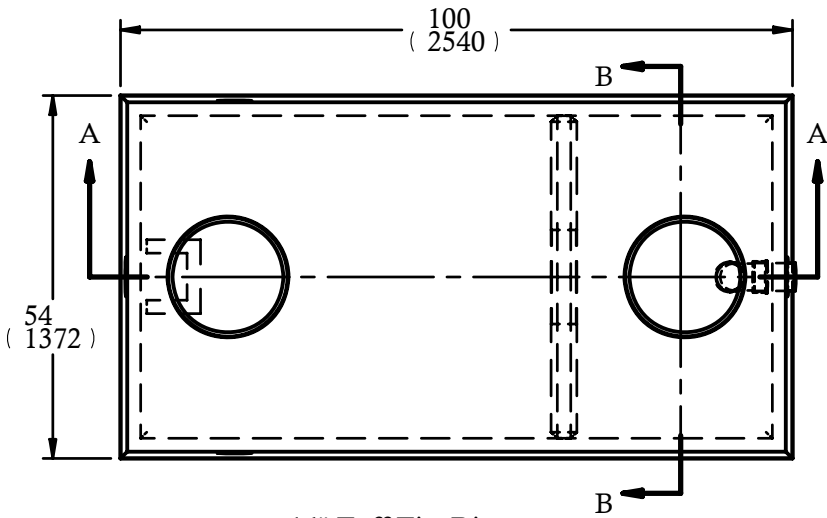

Delivery is made by crane-equipped trucks, excavation should be 1ft larger than tank dimensions and be accessible for unloading from the rear of the truck. Min overhead clearance of 18ft is required.

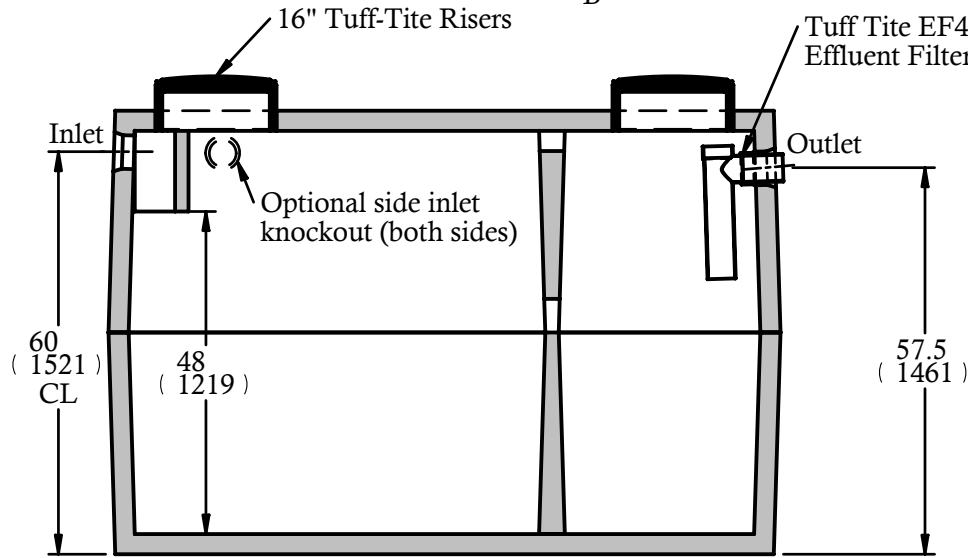
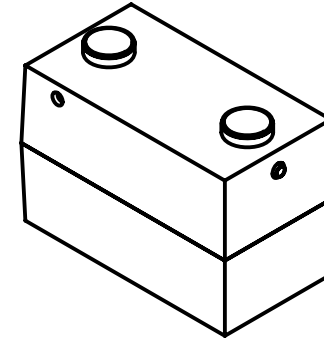

SECTION A-A

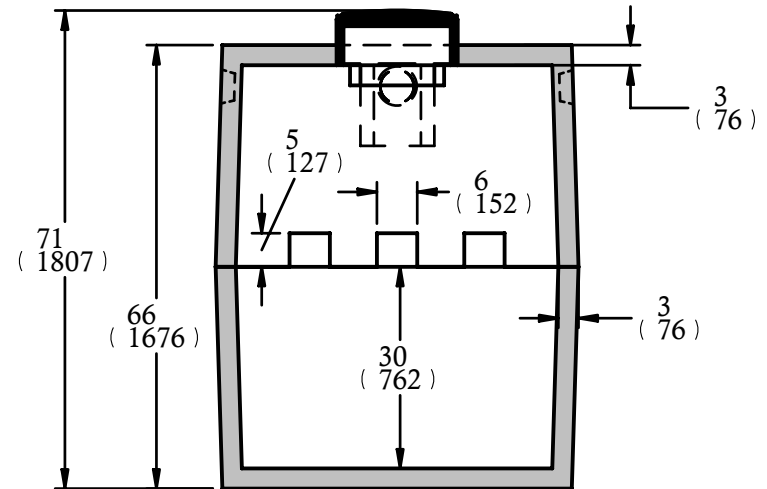

SECTION B-B

in
| mm |



CONSTRUCTION SPECIFICATIONS

Concrete Properties: 4500 PSI (32 MPa) Min Strength
 6-8% Air Entertainment
 Riser cover may be used with extensions
 Cast in place Inlet & Outlet baffles
 Inlet & Outlet Polyseals accept up to 4" ABS pipe
 Dimensions in inches and (mm)
 Meets CSA-B66-00
 Reinforcing meets G30.14-M1983

**800 Gallon
(3600 Litre)
Septic Tank**

Brooklin (800)655-3430
 Newmarket (888)407-6443
 Huntsville (800)264-3302
 Haliburton (800)273-9084

Max Cover: 30"	Unit Weight: 7,330 lbs
Model: 800-2CH-2PC	CPA CERTIFIED
DRAWN BY: TD	DATE: 17 February 2007