

Delivery is made by crane-equipped trucks, excavation should be 1ft larger than tank dimensions and be accessible for unloading from the rear of the truck. Min overhead clearance of 18ft is required.

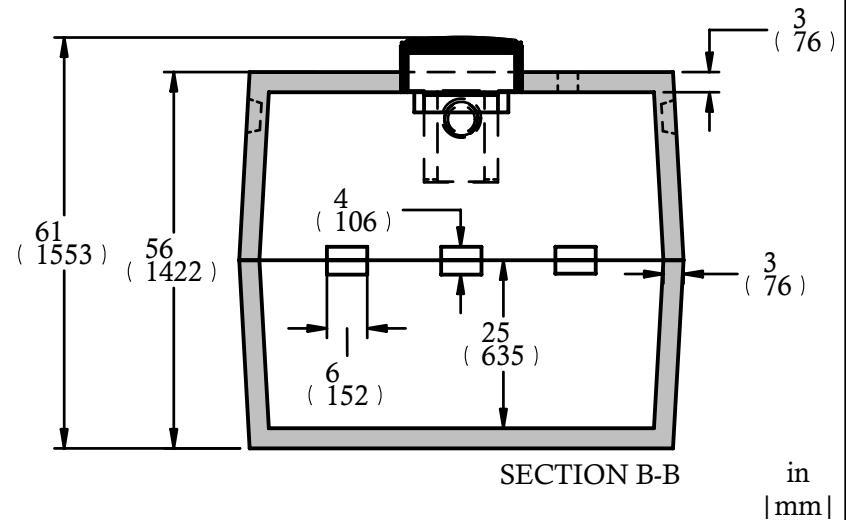
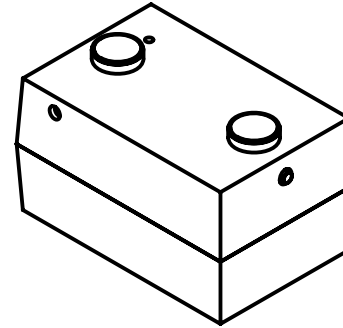

# Brooklin

CONCRETE

Brooklin (800)655-3430  
 Newmarket (888)407-6443  
 Huntsville (800)264-3302  
 Haliburton (800)273-9084

## CONSTRUCTION SPECIFICATIONS

Concrete Properties: 4500 PSI (32 MPa) Min Strength  
 6-8% Air Entertainment  
 Riser cover may be used with extensions  
 Cast in place Inlet & Outlet baffles  
 Inlet & Outlet Polyseals accept up to 4" ABS pipe  
 Dimensions in inches and (mm)  
 Meets CSA-B66-00  
 Reinforcing meets G30.14-M1983

800 Gallon  
 (3600 Litre)  
 Septic Tank

Low  
 Height

Max Cover: 30"	Unit Weight: 7,430 lbs
Model: 800-2CH-2PC low	CPA CERTIFIED
DRAWN BY: TD	DATE: 17 February 2007

Drawn by: RM
Date: FEB / 2002
REVISIONS:
Feb 2004 - RM
Feb 2005 - RM
Jan 2007 - TD
Feb 2007 - TD