

Delivery is made by crane-equipped trucks, excavation should be 1ft larger than tank dimensions and be accessible for unloading from the rear of the truck. Min overhead clearance of 18ft is required.

Drawn by: KP
Date: FEB / 2002
REVISIONS:
Feb 2004 - RM
Feb 2005 - RM
Dec 2005 - RM
Feb 2006 - RM
Jan 2007 - TD

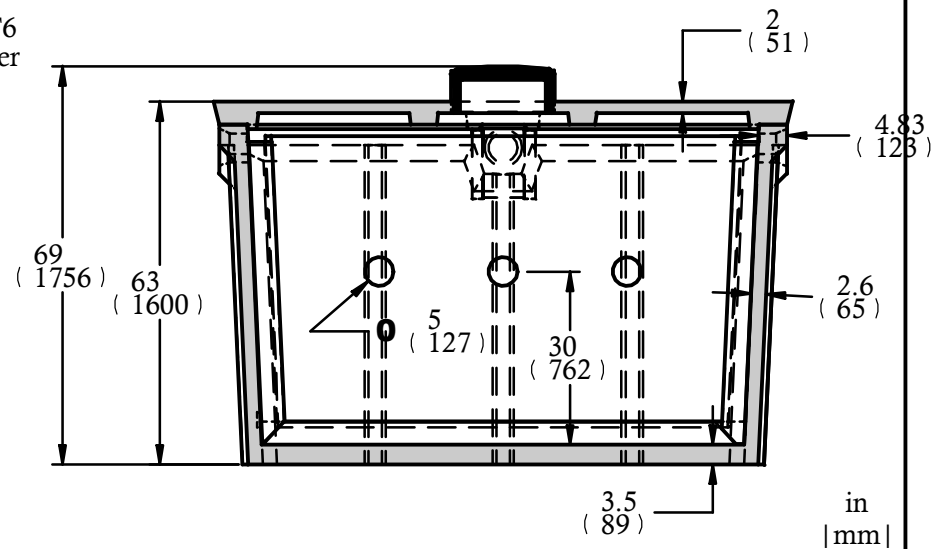
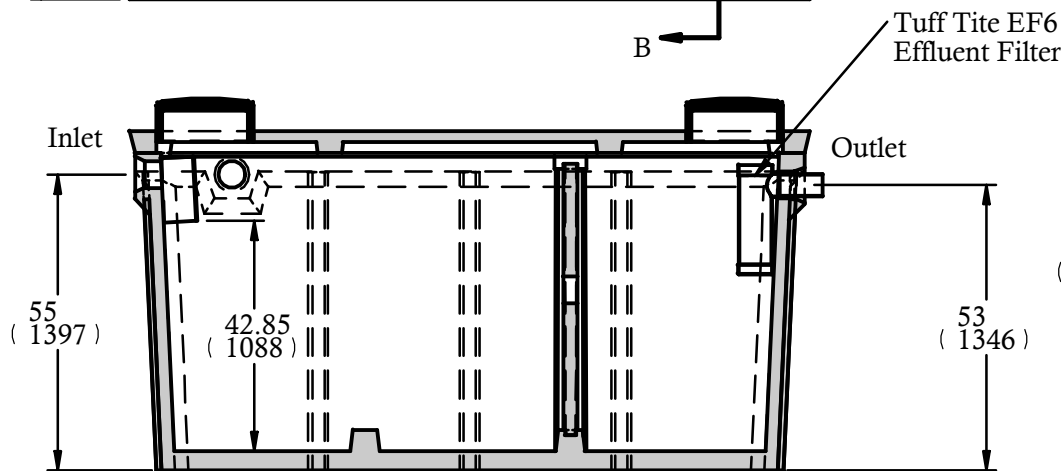
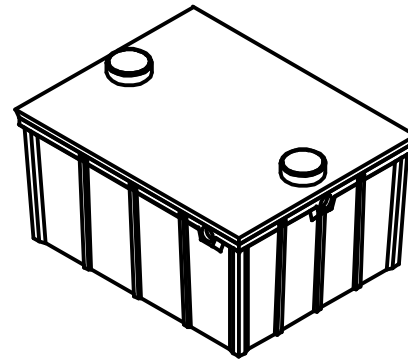

Brooklin
CONCRETE

Brooklin (800)655-3430
Newmarket (888)407-6443
Huntsville (800)264-3302
Haliburton (800)273-9084

CONSTRUCTION SPECIFICATIONS

Concrete Properties: 4500 PSI (32 MPa) Min Strength
6-8% Air Entertainment
Riser cover may be used with extensions
Plastic Inlet & Outlet baffles
Inlet & Outlet Polyseals accept up to 4" ABS pipe
Dimensions in inches and (mm)
Meets CSA-B66-00
Reinforcing meets G30.14-M1983

**1550 Gallon
(7000 Litre)
Septic Tank**

Max Cover: 30"	Unit Weight: 14,460 lbs
Model: 1550-2CH-IPC	CPA CERTIFIED
DRAWN BY: TD	DATE: 5 January 2007