

Delivery is made by crane-equipped trucks, excavation should be 1ft larger than tank dimensions and be accessible for unloading from the rear of the truck. Min overhead clearance of 18ft is required.

Drawn by: RM
Date: FEB / 2002
REVISIONS:
Feb 2004 - RM
Feb 2005 - RM
Feb 2006 - RM
Feb 2007 - TD

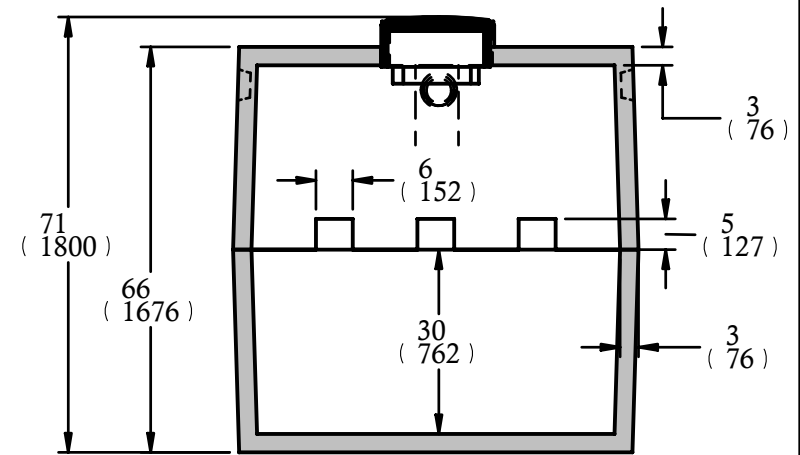
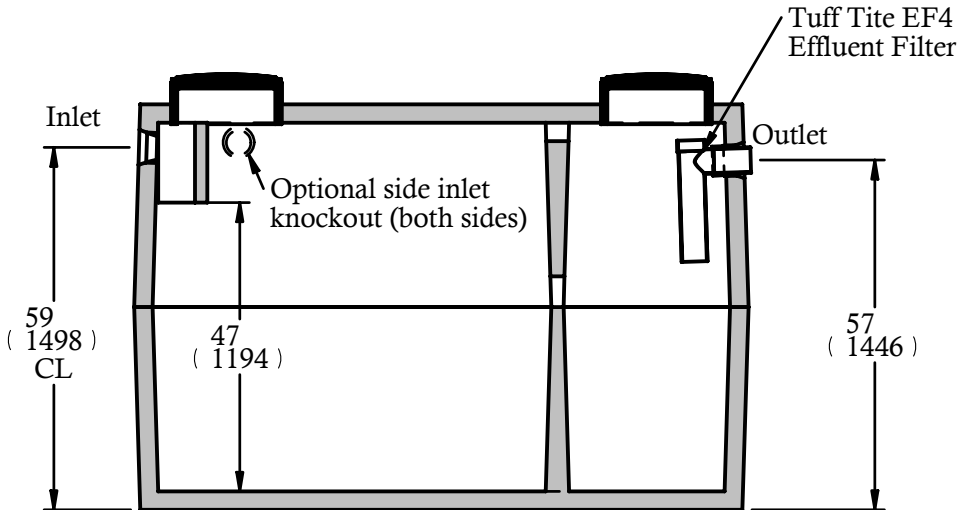
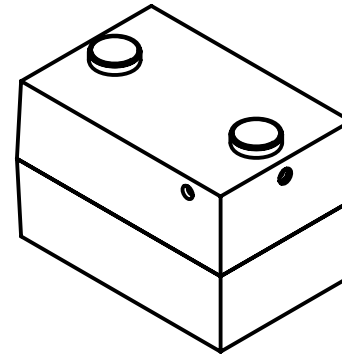

SECTION A-A

SECTION B-B

in
| mm |

Brooklin
CONCRETE

Brooklin (800)655-3430
Newmarket (888)407-6443
Huntsville (800)264-3302
Haliburton (800)273-9084

CONSTRUCTION SPECIFICATIONS

Concrete Properties: 4500 PSI (32 MPa) Min Strength
6-8% Air Entertainment
Riser cover may be used with extensions
Cast in place Inlet & Outlet baffles
Inlet & Outlet Polyseals accept up to 4" ABS pipe
Dimensions in inches and (mm)
Meets CSA-B66-00
Reinforcing meets G30.14-M1983

**1000 Gallon
(4500 Litre)
Septic Tank**

Max Cover: 30"	Unit Weight: 8,700 lbs
Model: 1000-2CH-2PC	CPA CERTIFIED
DRAWN BY: TD	DATE: 18 February 2007