

Delivery is made by crane-equipped trucks, excavation should be 1ft larger than tank dimensions and be accessible for unloading from the rear of the truck.
Min overhead clearance of 13ft is required.

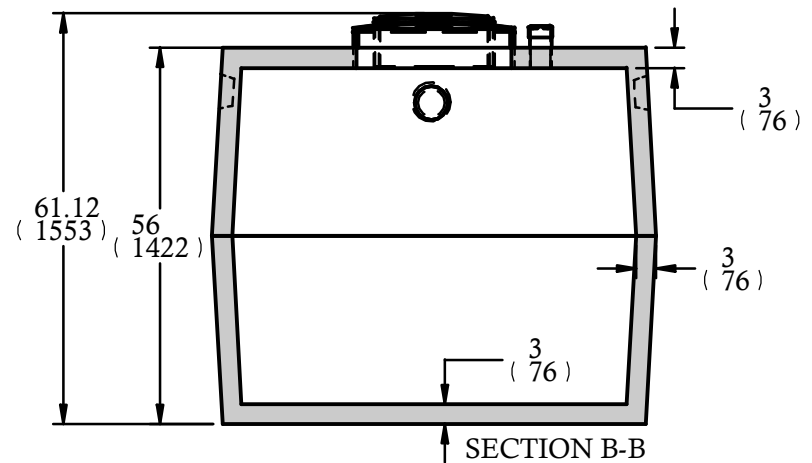
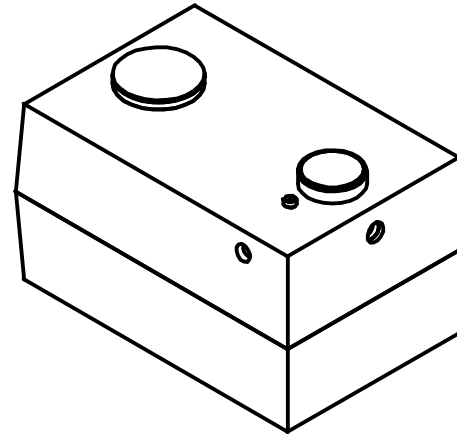

Drawn by: RM
Date: FEB / 2002
REVISIONS:
Feb 2004 - RM
Feb 2005 - RM
Feb 2006 - RM
Dec 2006 - TD
Feb 2007 - TD

Brooklin
CONCRETE

Brooklin (800)655-3430
Newmarket (888)407-6443
Huntsville (800)264-3302
Haliburton (800)273-9084

CONSTRUCTION SPECIFICATIONS

Concrete Properties: 4500 PSI (32 MPa) Min Strength
6-8% Air Entertainment
Riser cover may be used with extensions
Inlet Polyseal accepts up to 4" ABS pipe
18" Plastic (6" Dia) pumpout extension available
Dimensions in inches and (mm)
Meets CSA-B66-00
Reinforcing meets G30.14-M1983

**800 Gallon
(3600 Litre)
Single Tank**

**Low
Height**

Max Cover: 30"	Unit Weight: 8,000 lbs
Model: 800-1CH-2PC	CPA CERTIFIED
DRAWN BY: TD	DATE: 17 February 2007