

SECTION A-A

Delivery is made by crane-equipped trucks, excavation should be 1ft larger than tank dimensions and be accessible for unloading from the rear of the truck. Min overhead clearance of 18ft is required.

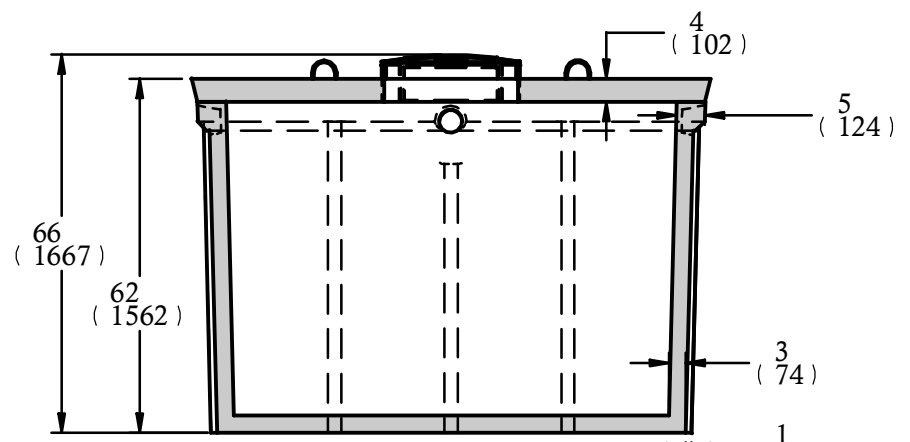
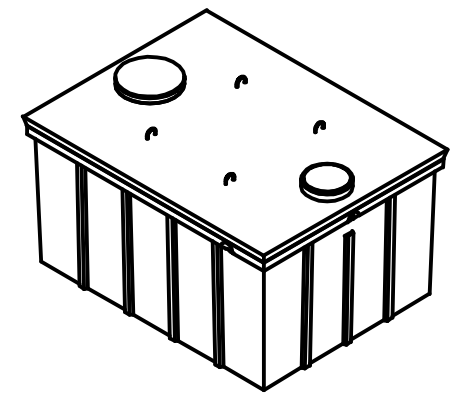

SECTION B-B

in  
| mm |

Drawn by: RM
Date: FEB / 2002
REVISIONS:
Feb 2004 - RM
Feb 2005 - RM
Feb 2006 - RM
Feb 2007 - TD

# Brooklin

CONCRETE

Brooklin	(800)655-3430
Newmarket	(888)407-6443
Huntsville	(800)264-3302
Haliburton	(800)273-9084

## CONSTRUCTION SPECIFICATIONS

Concrete Properties: 4500 PSI (32 MPa) Min Strength  
 6-8% Air Entertainment  
 Riser cover may be used with extensions  
 Inlet Polyseal accepts up to 4" ABS pipe  
 18" Plastic (6" Dia) pumpout extension available  
 Dimensions in inches and (mm)  
 Meets CSA-B66-00  
 Reinforcing meets G30.14-M1983

# 1350 Gallon (6135 Litre) Holding Tank

Max Cover: 30"	Unit Weight: 12,600 lbs
Model: 3000-1CH-1PC	CPA CERTIFIED
DRAWN BY: TD	DATE: 18 February 2007