

Brooklin (800)655-3430  
 Newmarket (888)407-6443  
 Huntsville (800)264-3302  
 Haliburton (800)273-9084

**MicroFAST 0.75**  
**Flow Rate: 2,850 L/day**



Tank Arrangement Drawing  
 Tank Model: 1500-2PC-2CH

DRAWN BY: TD  
 DATE: 24 February/2007

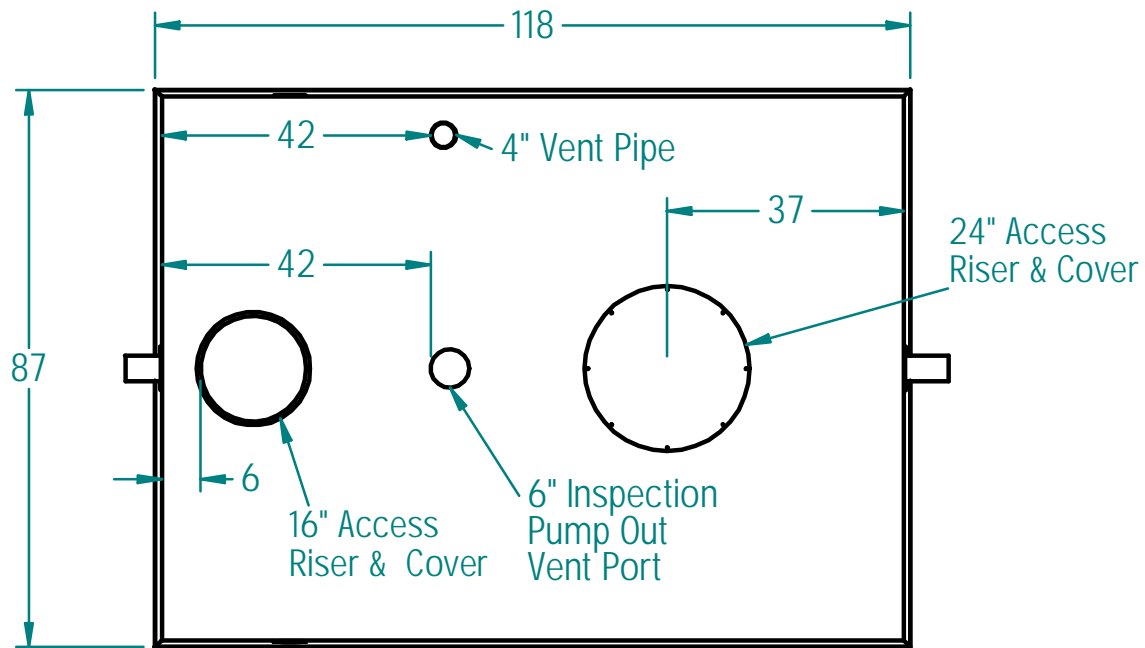

TANK LID PLAN VIEW

MicroFAST Model MCF 0.75

Daily Maximum Residential Sewage Flow:  
625 imp gal  
2850 L

Maximum Biological Loading Rates:  
250mg/L BOD  
250mg/L TSS  
<35mg/L Fat's, Oil's, Grease

Effluent Quality:  
10mg/L BOD  
10mg/L TSS  
70% Reduction Total Nitrogen

Blower  
1/3hp, 230v, 1ph or 3ph,  
22-25 CFM Atmospheric Air

CONSULT PINNACLE FOR ALL  
HIGH STRENGTH APPLICATIONS  
(BOD or TSS > 250mg/L)

The Tongue & Groove Joint Is Sealed With Flexible Butyl Resin Sealant During Production

24' of Equalizer 24 Chambers & 4 End Caps to be Installed With Each Unit For In Ground Venting.

**Maximum Burial Depth Of The Infiltrator Is 15" (380mm)**

Concrete Properties: 4500 PSI (32 MPa) Min Strength  
6-8% Air Entertainment

NonSulphate Soil Design Concrete

**Maximum Burial Depth Of The Tank Is 30" (750mm)**

Inlet & Outlet Polyseals Accept Up To 4" ABS Pipe

Shipping Weight: 13,500 lbs

in  
| mm |



Brooklin (800)655-3430  
Newmarket (888)407-6443  
Huntsville (800)264-3302  
Haliburton (800)273-9084

MicroFAST 0.75  
Flow Rate: 2,850 L/day



Lid Plan View & Notes  
Tank Model: 1500-2PC-2CH

DRAWN BY: TD

DATE:24 February/2007