

Delivery is made by crane-equipped trucks, excavation must be ready, safe and accessible for unloading from the rear of the truck. Min overhead clearance of 18ft is required. ALL UNITS MUST BE HANDLED WITH PROPER LIFTING EQUIPMENT . (I.E. SPREADER BAR)

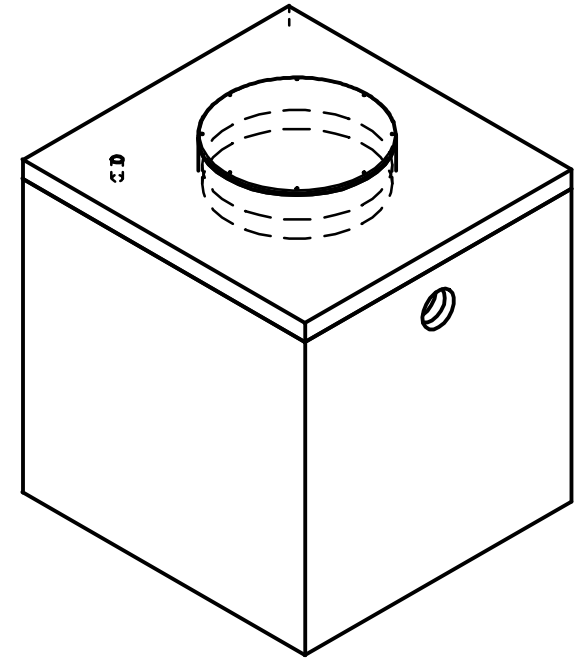

Kit Includes

- 1 - 300 Gal tank
- 1 - 12 x 12 Patio Slab
- 1 - PE41 P1 Pump
- 1 - MPC-30 P500 Level alarm

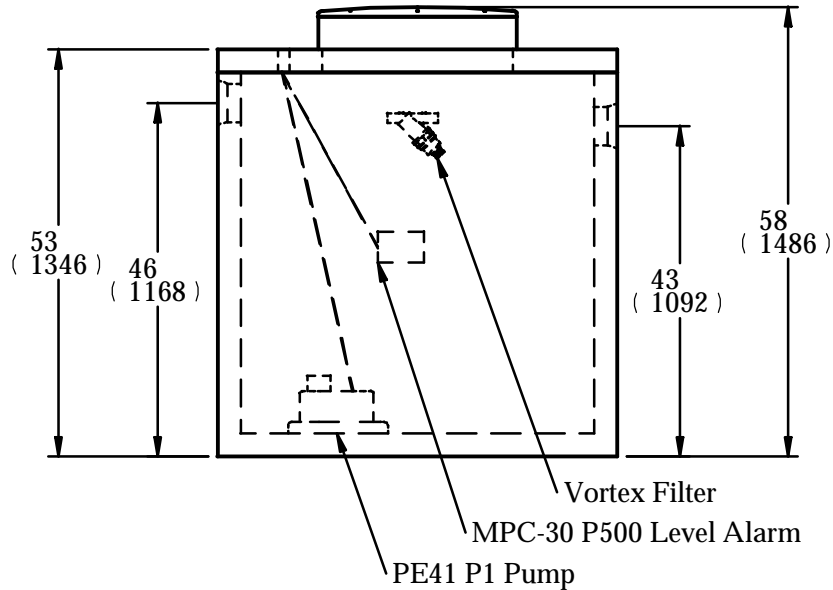

Max Cover: 30"

in
| mm |



CONSTRUCTION SPECIFICATIONS

Concrete Properties: 4500 PSI (32 MPa) Min Strength
6-8% Air Entertainment

Inlet & outlet polyseals accept up to 4" ABS pipe

300 Gal
Vortex Filter Package

Brooklin (800)655-3430
Newmarket (888)407-6443
Huntsville (800)264-3302
Haliburton (800)273-9084

Unit Weight: 3,650 lbs

DRAWN BY: TD

DATE: 30 October 2006