

CORNER VERTICAL & VERTICAL CONNECTORS GREATER THAN 3758 LG ARE BUILT UP AS FOLLOWS (UNLESS NOTED)

4167 LG	-1x3658
1x509	1 WEB SPLICE PLATE
4572 LG	-1x3658
1x914	1 WEB SPLICE PLATE
4977 LG	-1x3658
1x1320	1 WEB SPLICE PLATE
5386 LG	-1x3658
1x1728	1 WEB SPLICE PLATE
5791 LG	-1x3658
1x2134	1 WEB SPLICE PLATE
6197 LG	-1x3658
1x2539	1 WEB SPLICE PLATE
6605 LG	-1x3658
1x2947	1 WEB SPLICE PLATE
7010 LG	-1x3658
1x3353	1 WEB SPLICE PLATE
7416 LG	-1x3658
1x3758	1 WEB SPLICE PLATE
7824 LG	-2x3658
1x509	2 WEB SPLICE PLATES
8320 LG	-2x3658
1x914	2 WEB SPLICE PLATES
8635 LG	-2x3658
1x1320	2 WEB SPLICE PLATES

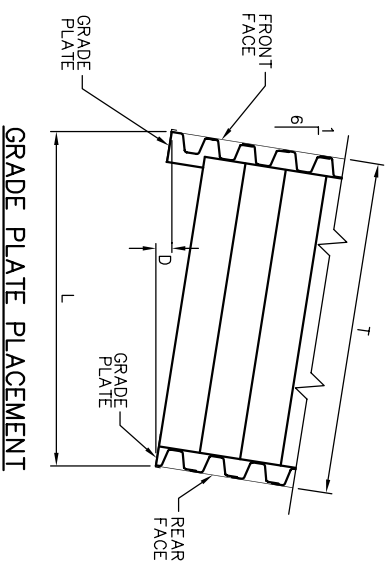

WALL DESIGN	T	D	L
A	1689	-124 *	1734
B	2362	-13 *	2397
C	3035	98	3064
D	3708	210	3724
E	4382	318	4391
F	5055	429	5055

\* FRONT GRADE PLATE LOWER THAN REAR PLATE

MAXIMUM HEIGHTS AND LOADS FOR UNBRACED SPACER WALLS

BIN DESIGN	(p max) ALLOWABLE		MAXIMUM HEIGHT WITHOUT BRACING	
	psf	k Pa	ft	mm
A	1728	83	48.0	14630
B	728	35	20.2	6160
C	498	24	13.8	4215
D	438	21	12.2	3715
E	301	14	8.4	2550
F	220	11	6.1	1860

MAXIMUM ALLOWABLE PRESSURE ON EXPOSED SPACER WALLS (p max) BASED ON LENGTH OF SPACER AND SECTION MODULUS.

MAXIMUM HEIGHT WITHOUT BRACING BASED ON SOIL DENSITY = 19 kN/m<sup>3</sup> (120pcf) AND  $\phi=33^\circ$  AND NO LIVE LOAD SURCHARGES.

STRINGER LOCATION & PART NO.

FRONT WALL STRINGER LOCATION	REAR WALL STRINGER LOCATION	THK mm	PART NO. STANDARD STRINGER	PART NO. SHORT STRINGER
1 THROUGH 8	1 THROUGH 6	1.6	WSA1601	WSB1601
9 THROUGH 12	7 THROUGH 10	2.0	WSA2001	WSB2001
13 THROUGH 19	11 THROUGH 17	2.8	WSA2801	WSB2801
20 AND 21	18 AND 19	3.5	WSA3501	WSB3501

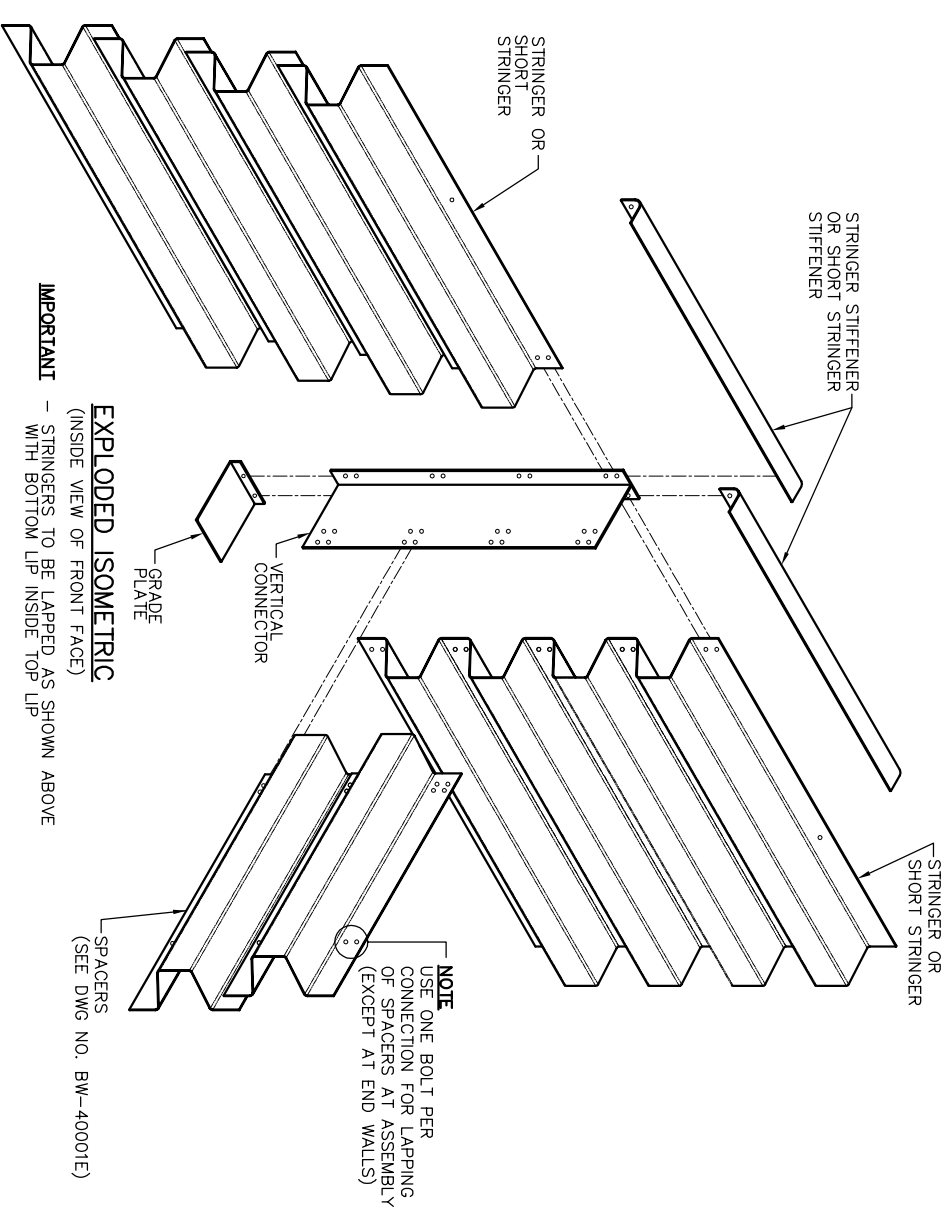

IMPORTANT - STRINGERS TO BE LAPPED AS SHOWN ABOVE WITH BOTTOM LIP INSIDE TOP LIP

NOTES

- 1) BACKFILL MATERIAL TO BE WELL-GRADED FREE-DRAINING GRANULAR MATERIAL, WITH LARGEST PARTICLES IN THE 75mm (MAX) RANGE AND NOT MORE THAN 10 PERCENT FINES PASSING THE NO.200 SIEVE (0.075mm).
- 2) BACKFILL SHOULD BE PLACED IN 200mm LAYERS (MAX) AND COMPACTED TO 95 PERCENT STANDARD PROCTOR DENSITY.
- 3) THE HEIGHT OF BACKFILL INSIDE THE BINS SHOULD BE AT LEAST 400mm GREATER THAN THE BACKFILL BEHIND THE BINS DURING THE BACKFILLING OPERATIONS.
- 4) FILL ALL CORRUGATIONS IN SPACERS AND STRINGERS, BUT CARE MUST BE EXERCISED TO AVOID DAMAGING THE STRINGERS WITH DUMPING OR COMPACTING EQUIPMENT, WHICH SHOULD BE KEPT AT LEAST 300mm FROM THE FRONT STRINGERS.
- 5) ADEQUATE DRAINAGE BEHIND THE WALL MUST BE ENSURED BY USING A PERFORATED CSP DRAINAGE SYSTEM OR EQUAL.
- 6) IF THE BINWALL IS TO SIT ON AN UNYIELDING FOUNDATION, A MINIMUM CUSHION OF 200mm THICK NON-COMPACTED GRANULAR MATERIAL MUST BE PLACED UNDER THE GRADE PLATES.
- 7) FOR HINTS ON ERECTION AND BACKFILL SEQUENCE SEE THE SUPPLIED ARMETEC INSTALLATION MANUAL.

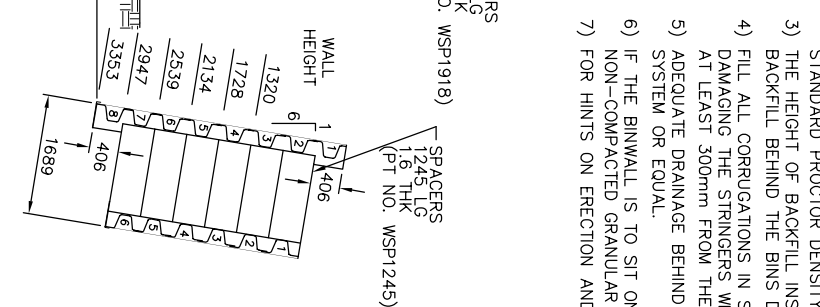
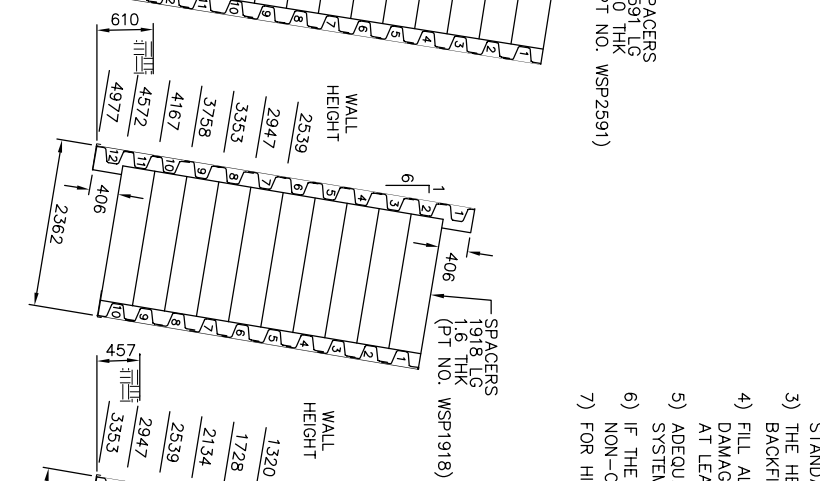
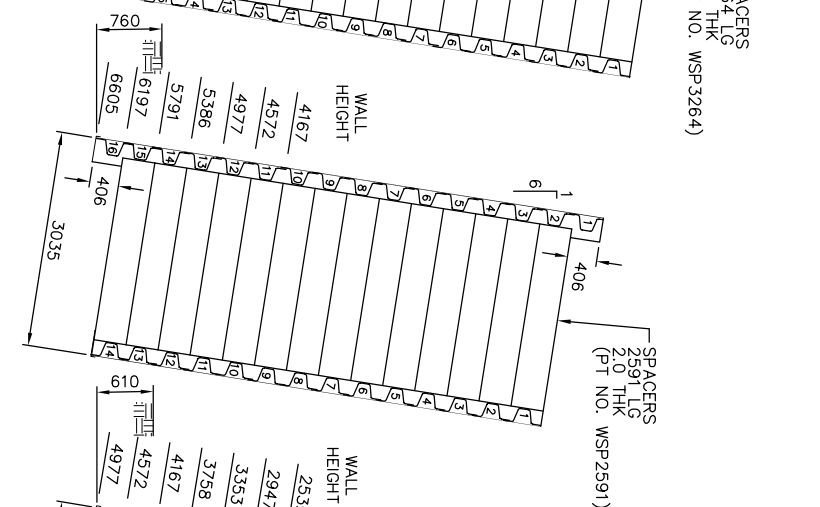
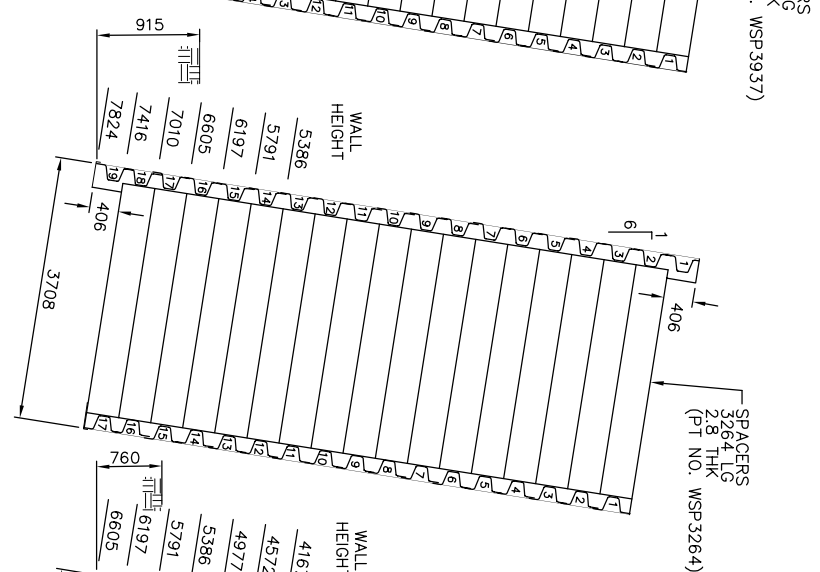
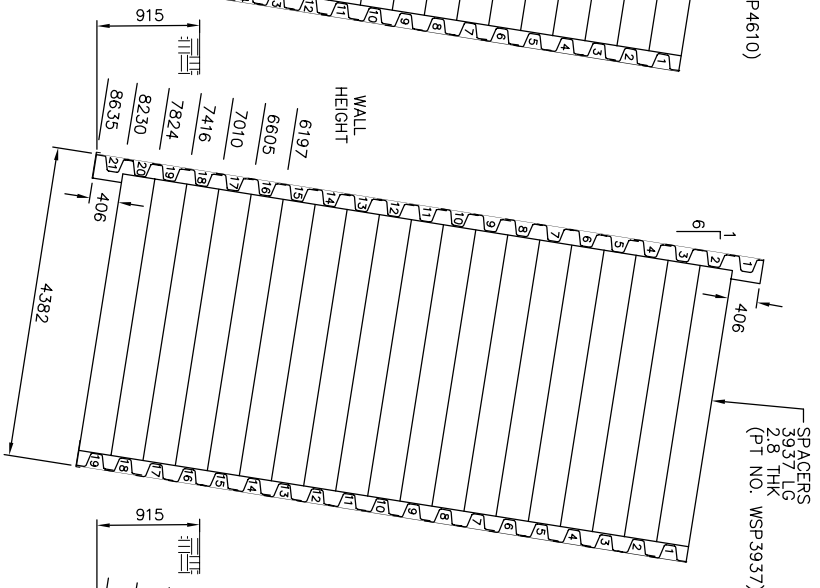
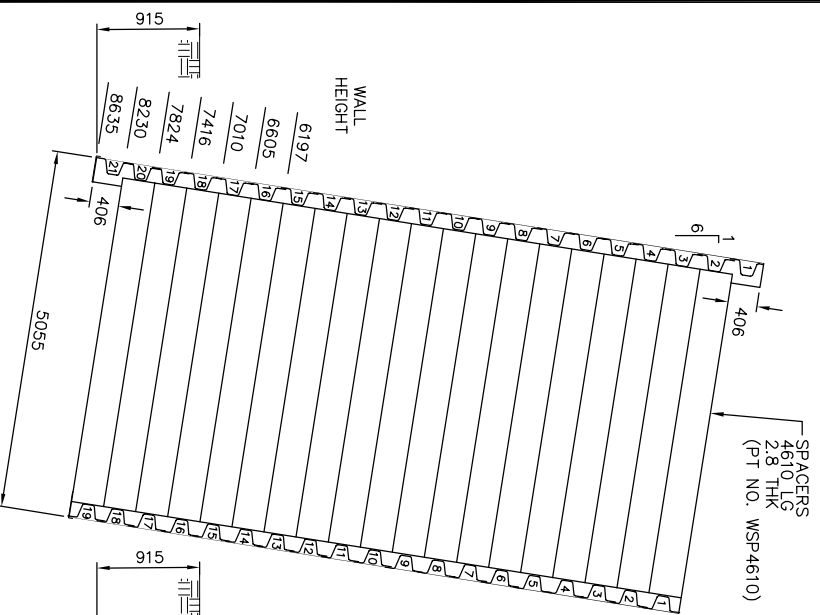

DESIGN F

DESIGN E

DESIGN D

DESIGN C

DESIGN B

DESIGN A

NO.	DATE	DESCRIPTION OF REVISION	BY	CHK'D
3	2005/11/00	UPDATED BORDER	JW	KA
2	DEC 7/87	NEW DRAWING NO. & REVISED COMPANY NAME	KA	KA
1				

THIS DRAWING IS THE PROPERTY OF  
**ARMETEC LIMITED PARTNERSHIP**  
AND IS LENT WITHOUT CONSIDERATION OTHER THAN THE BORROWER'S AGREEMENT THAT IT SHALL NOT BE REPRODUCED, COPIED, LENT OR DISPOSED OF DIRECTLY OR INDIRECTLY, NOR USED FOR ANY PURPOSE OTHER THAN THAT FOR WHICH IT IS SPECIFICALLY FURNISHED. THIS PRINT IS LENT SUBJECT TO RETURN ON DEMAND.

BIN-TYPE RETAINING WALL	DATE	DRAWN
TYPE 2	CHECKED	
STANDARD DEPTH & HEIGHT	REVIEWED	
COMBINATIONS	SCALE	NTS

TAG NO.	ORDER NO.
QUANTITY	DRAWING NO.
WT	<b>BW-40002_E</b>
	REV
	<b>3</b>
	SHEET
	2 OF 2

